

# askona

СПИТЕ, ЧТОБЫ ЖИТЬ

Инструкция

по сборке шкафа трехдверного с ящиками

Stefania (Стефания)

099\*150\*042

214H002, 214H012

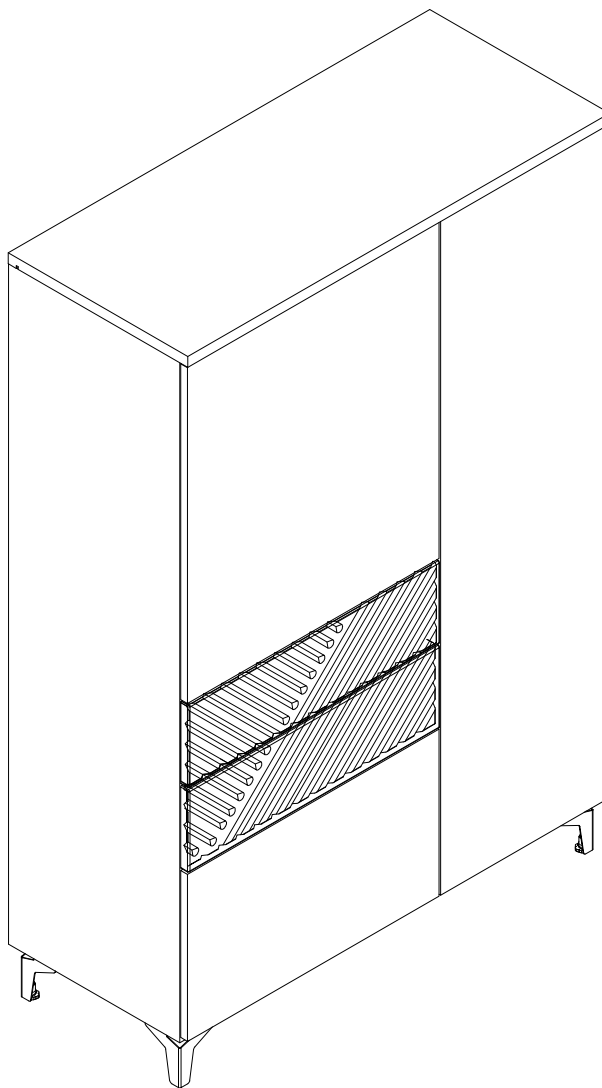

ТР ТС 025/2012

Декларация о соответствии ЕАЭС № ВУ/112 11.01. ТР025 009.01 01714  
от 29.04.2023 г., действительна до 28.04.2028 г. включительно

Телефон горячей линии 8 800 200 40 90 | Звонки по России бесплатные

ASKONA.RU

## Перед сборкой

1. Проверить вид и целостность деталей в упаковке. Претензии по их повреждению принимаются только у изделий БЕЗ следов сборки.
2. Сохраните упаковку до окончания сборки! При выявлении в процессе сборки брака и некомплектности изделия необходимо сохранить упаковку до момента выезда к Вам представителя торговой компании.
3. Проверьте количество деталей и фурнитуры по перечню комплекточной ведомости, разберите фурнитуру на группы. Предприятие-изготовитель оставляет за собой право вносить конструктивные изменения в изделие, заменять фурнитуру и метизы на аналогичные, не ухудшающие внешний вид и не влияющие на функциональные свойства изделия.
4. Соблюдайте порядок сборки, данный в этой инструкции! При несоблюдении инструкций по сборке и эксплуатации с компании-производителя снимаются гарантийные обязательства. Инструкции по сборке и эксплуатации необходимо сохранять на весь период эксплуатации изделия.
5. Перемещайте все детали бережно, без рывков, укладывайте устойчиво, избегайте их падений и ударов! Сборку изделия проводить на ровной поверхности.

## Для сборки вам понадобится:

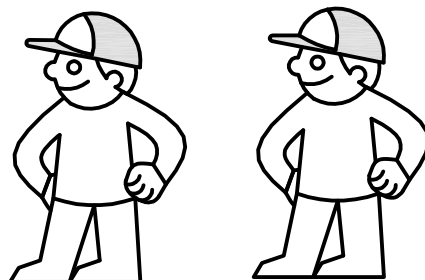
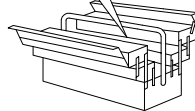
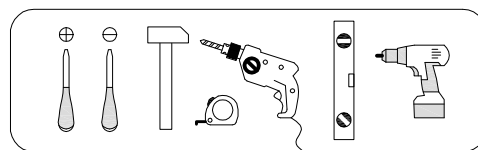

<b>RU</b>	Чтобы предотвратить опрокидывание, <b>ВСЕГДА</b> крепите мебель к стене! Входящие в комплект поставки материалы для крепления на стене (дюбели и шурупы) предназначены только для прочных бетонных стен. Для других типов стен используйте специальные дюбели и шурупы. При необходимости обратитесь за помощью в специализированный магазин.
<b>GB</b>	The enclosed wall mounting materials (dowels and screws) are only suitable for solid masonry (e.g. concrete or brick walls). Special dowels and other screws may be necessary for other wall constructions. If necessary, please consult a qualified professional.
<b>D</b>	Das beidseitig angebrachte Wandbefestigungsmaterial (Dübel und Schrauben) eignet sich nur für festes Mauerwerk (z.B. Beton oder Ziegelwände). Für andere Wandaufbauten sind eventuell Spezialdübel und andere Schrauben notwendig. Ziehen Sie gegebenenfalls eine Fachkraft zurate.
<b>FR</b>	Le matériel de fixation murale fourni (chevilles et vis) convient uniquement à des murs solides (p. ex. murs en béton ou en briques). Pour les autres constructions de murs, il faut éventuellement des chevilles spéciales et d'autres vis. Faites-vous conseiller par un spécialiste.
<b>IT</b>	I materiali di fissaggio allegati (tasselli e viti) sono adatti solo ai muri compatti (ad es. di calcestruzzo o mattoni). Per altri tipi di pareti è probabile che occorrono tasselli speciali e altre tipologie di viti. Richiedere eventualmente il consiglio di un esperto.
<b>NL</b>	Het bijgeleverde bevestigingsmateriaal (pluggen en schroeven) is geschikt voor vaste muren (bijv. betonnen of bakstenen muren). Voor andere muurconstructies zijn eventueel speciale pluggen en andere schroeven noodzakelijk. Consulteer eventueel een vakman.
<b>CZ</b>	Příložený materiál pro montáž na stěnu (hmoždinky a šrouby) je vhodný jen pro pevné zdivo (např. betonové nebo cihlové stěny). Pro jiné skladby stěn budou případně nutné speciální hmoždinky a jiné šrouby. Poradte s odborníkem.
<b>PL</b>	Żalączony zestaw montażowy do zamocowania artykułu do ściany (kołki, wkręty, haki itp.), przeznaczony jest do montażu artykułu na ścianach wykonanych z cegły lub betonu. Przy montażu artykułu na ścianie wykonanej z innych materiałów, należy zastosować odpowiednie do niej zamocowania. W razie wątpliwości prosimy zasięgnąć porady fachowca.
<b>SK</b>	Priložený materiál pre upevnenie na stenu (hmoždinky a skrutky) je vhodný len pre pevné murivo (napr. betónové alebo tehlové steny). Pre iné steny sú potrebné príp. špeciálne hmoždinky a iné skrutky. V prípade potreby sa poradte s odborníkom.
<b>HU</b>	A mellékelt fali rögzítőkészlet (tipli és csavarok) csak tömött falazatban (pl. betonfalban, téglafalban) használható. Más faltípusokhoz speciális tiplire és csavarra lesz szükség. Szükség esetén kérje ki egy szakember véleményét.
<b>RO</b>	Materialul furnizat pentru montajul de perete (dibluri și șuruburi) este adecvat numai pentru zidărie solidă (de exemplu pereți din beton sau din cărămidă). Pentru alte structuri de pereți, este posibil să fie necesare dibluri special, precum și alte șuruburi. Dacă este necesar, consultați un specialist.
<b>TR</b>	Teslimat kapsamındaki duvar tipi sabitleme materyali (dübel ve vidalar) sadece beton ve tuğla duvarlar gibi sağlam duvar yapılar için uygundur. Başka duvar yapılar için özel dübeller veya başka vidalar gerekli. Gerekirse bir uzmandan yardım alın.

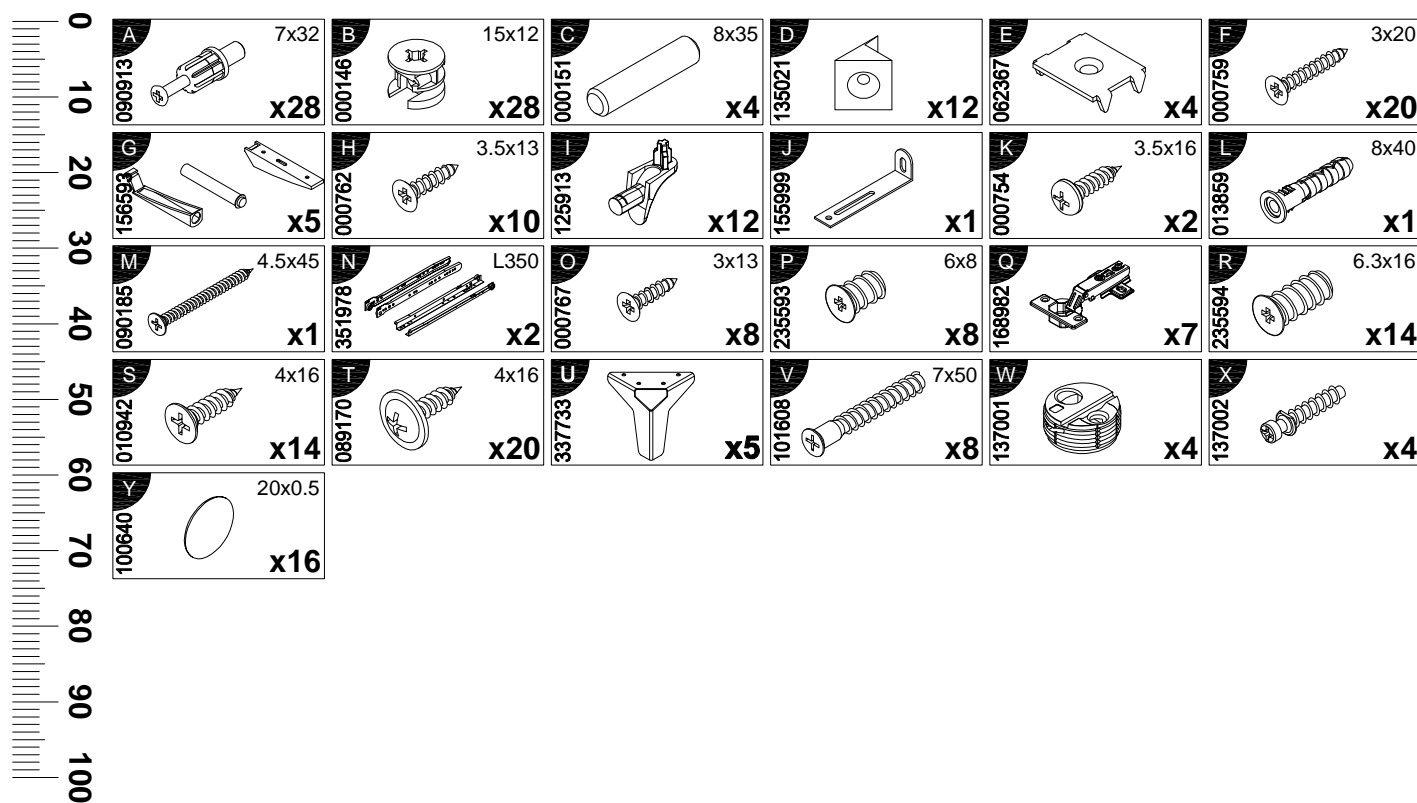

N	Size/MaB (mm)	Qty	✓	N	Size/MaB (mm)	Qty	✓
1	986x420x22	1	2	11	568x376x16	2	2
2	588x680x16	1	2	12	368x371x16	2	1
3	1364x388x16	1	1	13	588x167x19	1	2
4	338x588x16	1	2	13	588x167x19	1	2
5	952x376x16	1	1	14	1382x381x3	1	1
6	1378x400x16	1	1	15	1382x580x3	1	2
7	1378x400x16	1	1	16	350x120x16	2	2
8	1362x376x16	1	1	17	350x120x16	2	2
9	368x376x16	1	1	18	511x120x16	2	2
10	568x371x16	1	2	19	521x343x3	2	2

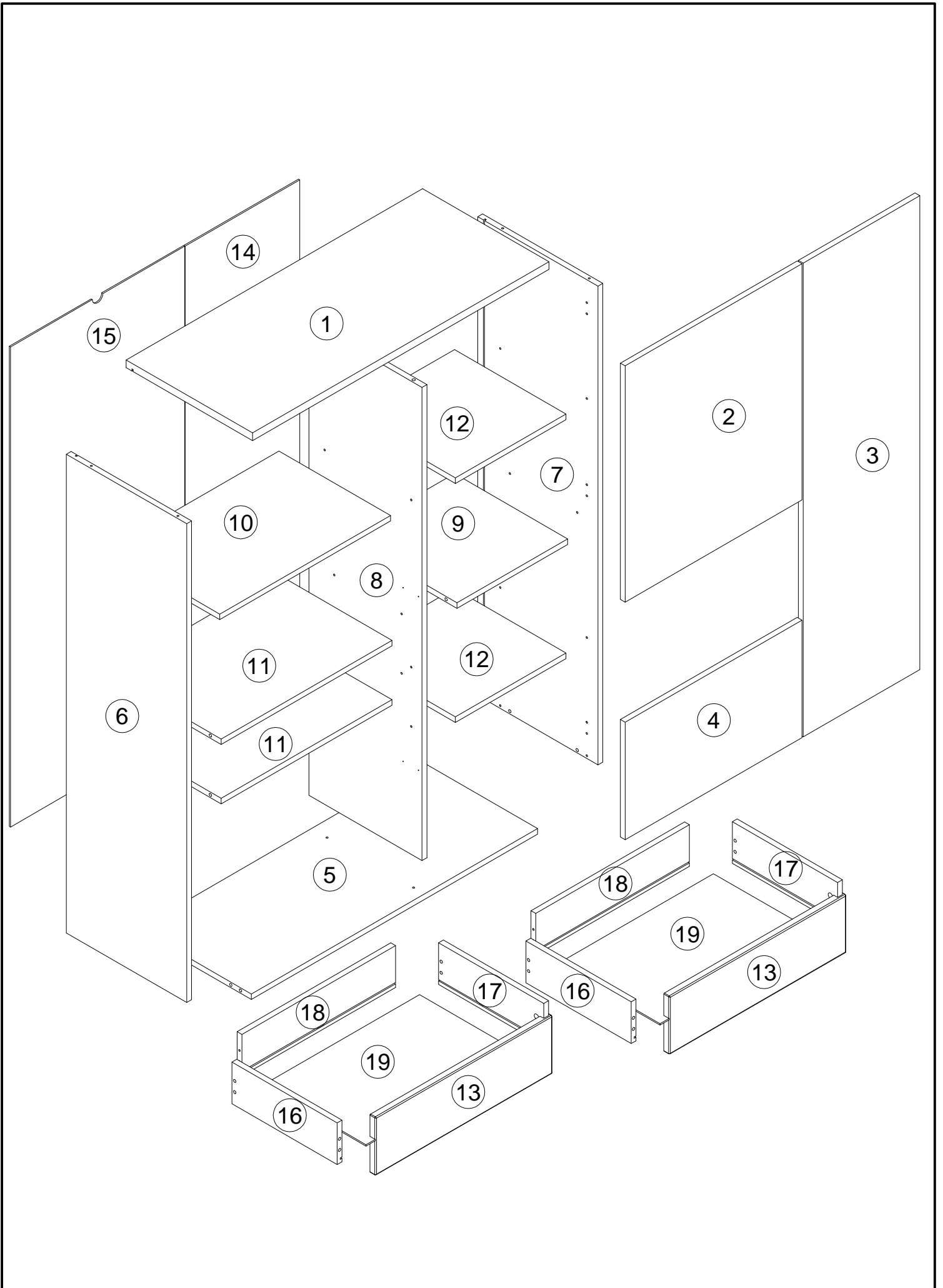

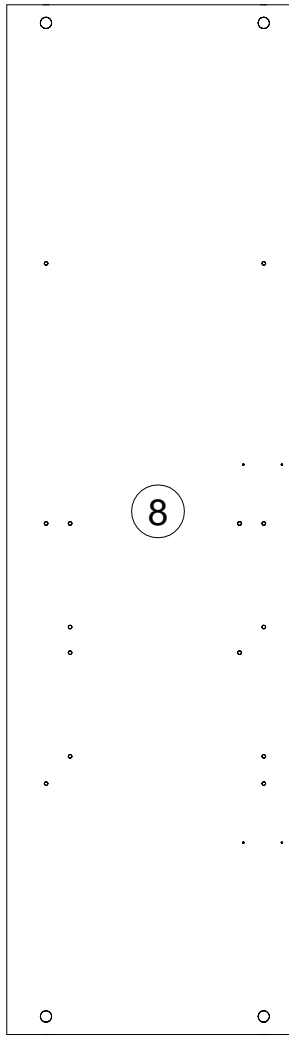

1362x376x16

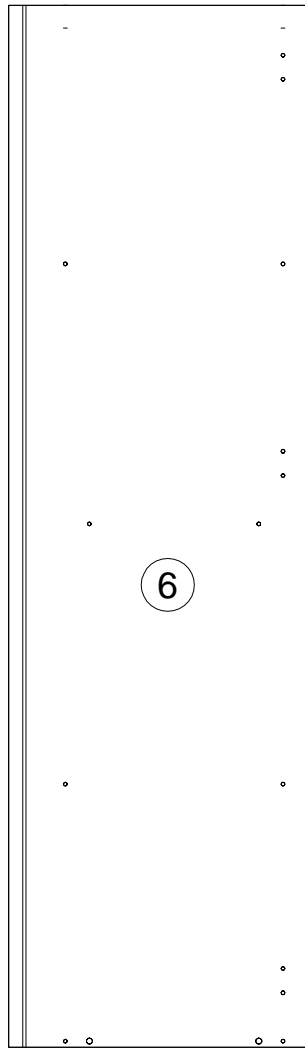

1378x400x16

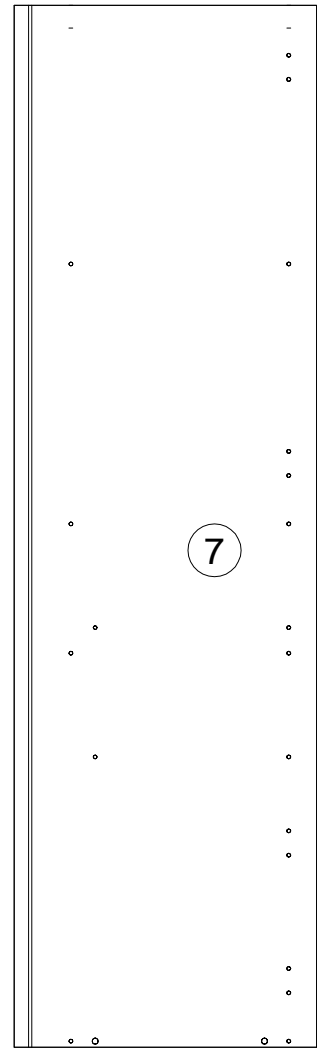

1378x400x16

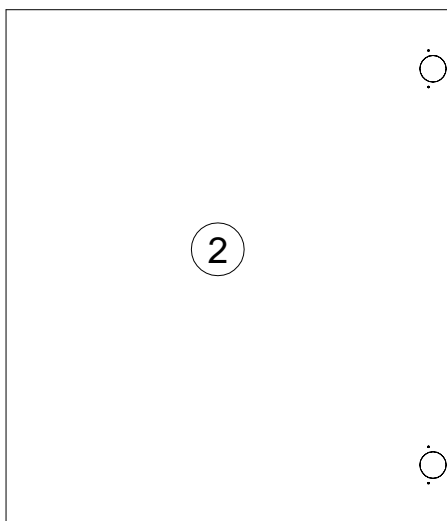

588x680x16

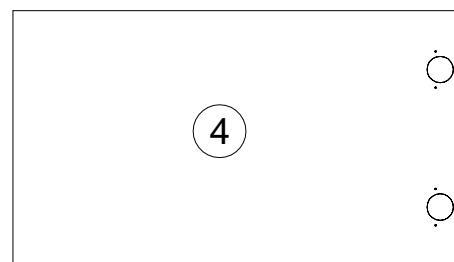

338x588x16

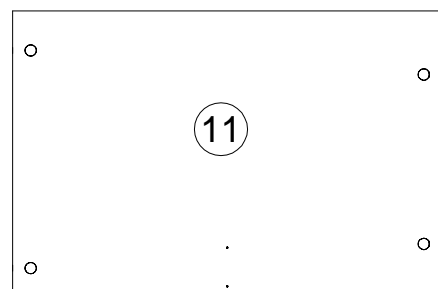

568x376x16

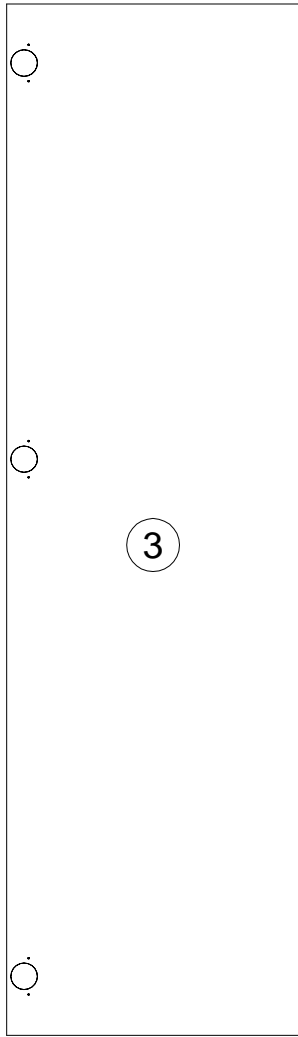

1364x388x16

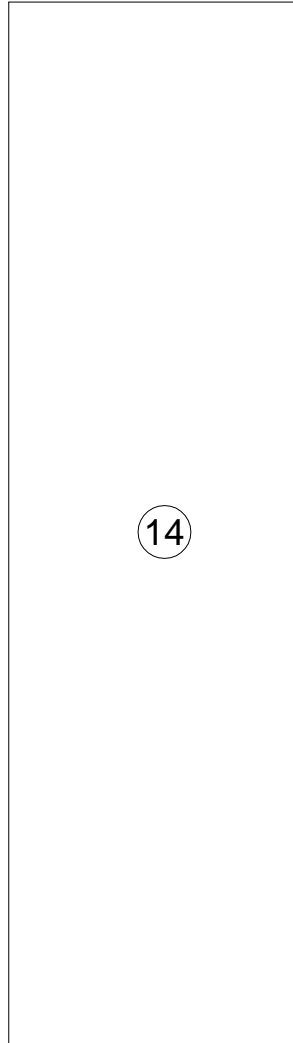

1382x381x3

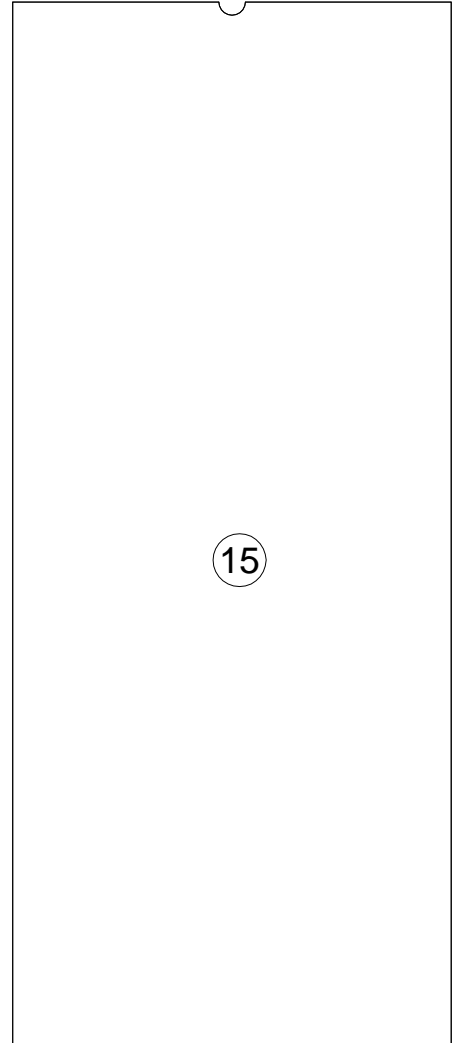

1382x580x3

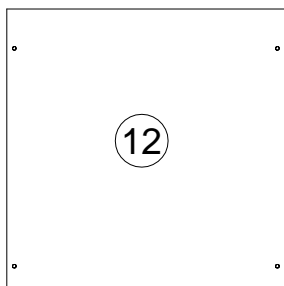

368x371x16

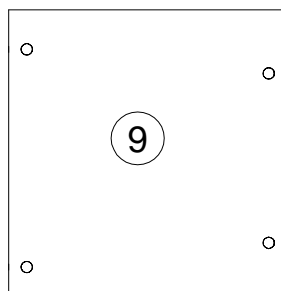

368x376x16

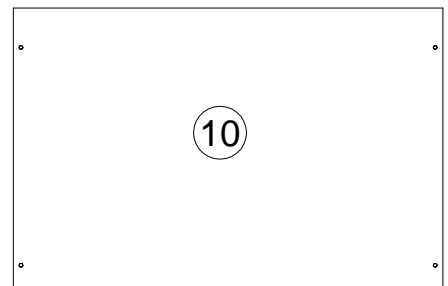

568x371x16

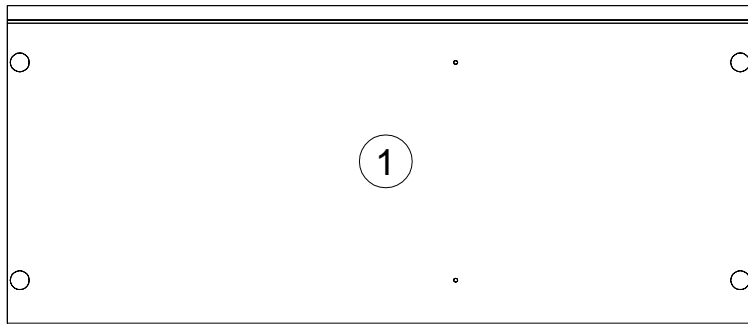

986x420x22

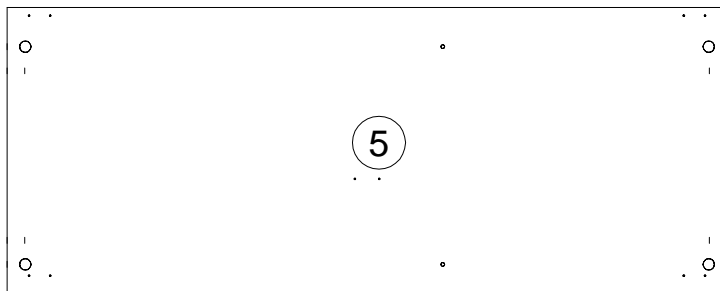

952x376x16

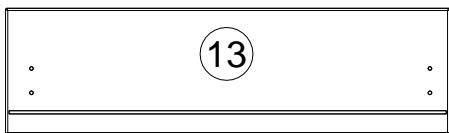
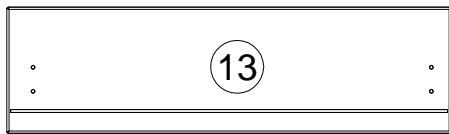

588x167x19

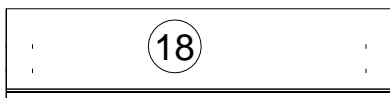

588x167x19

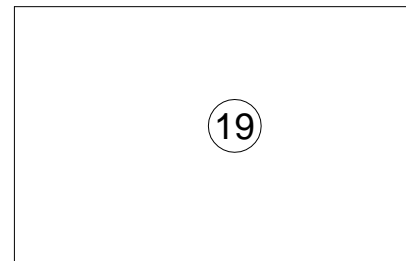

521x343x3

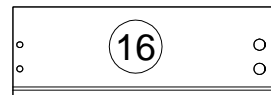

350x120x16

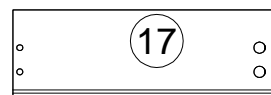

350x120x16



1

**A** 090913 7x32 x10

**I** 125913 x6

**N** 351978 L350 x2

**P** 235593 6x8 x4

**Q** 168982 x7

**R** 235594 6.3x16 x14

**X** 137002 x4

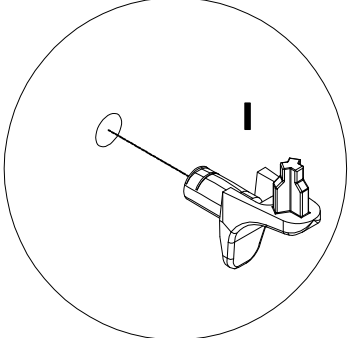
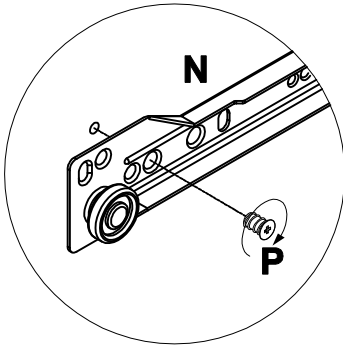
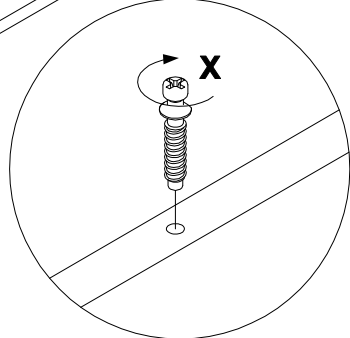
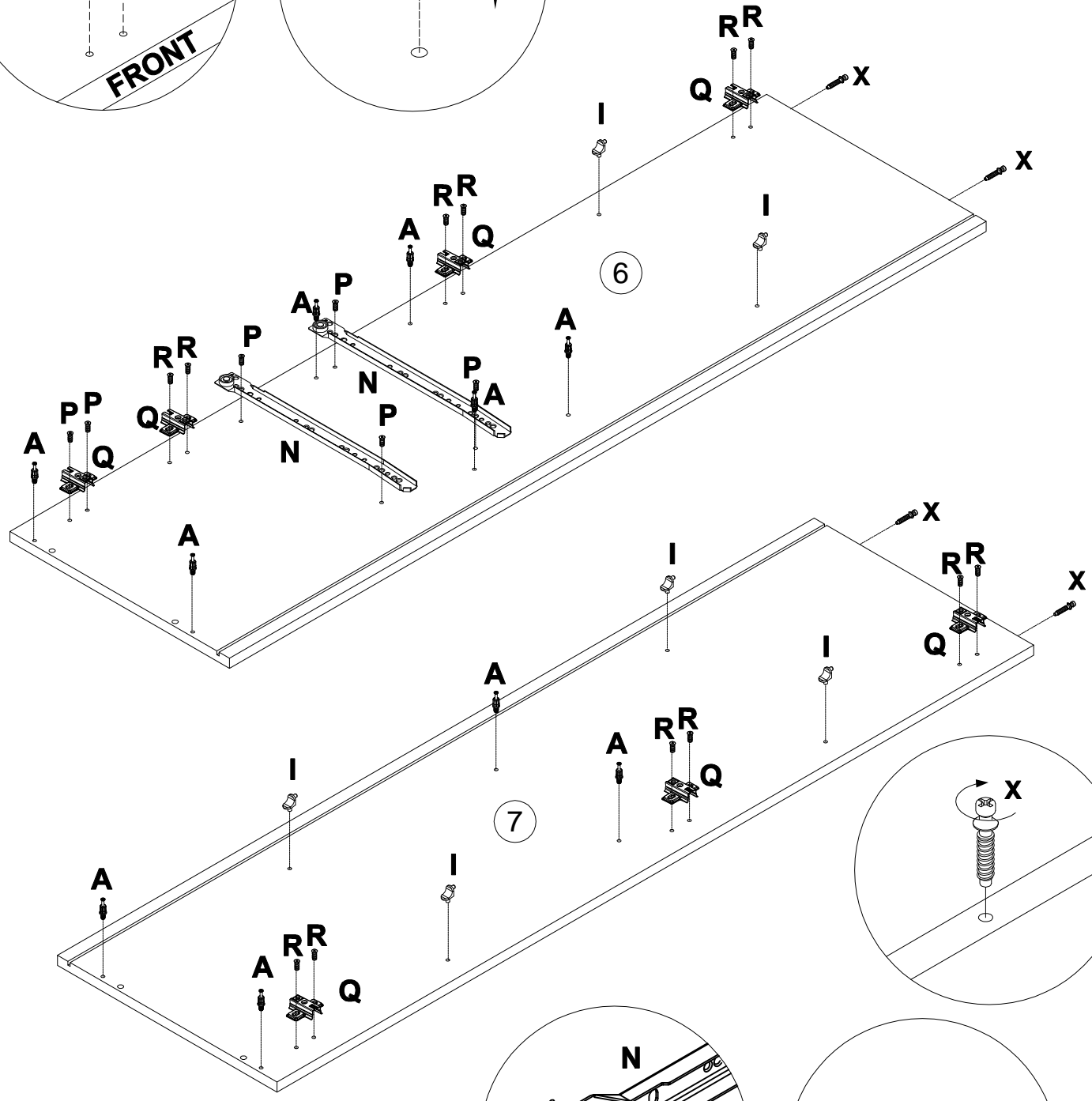
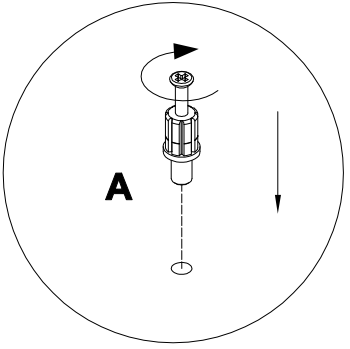
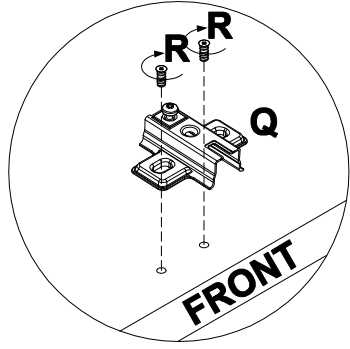

2

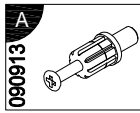

7x32  
x6

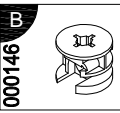

15x12  
x4

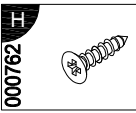
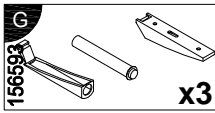

3.5x13  
x6

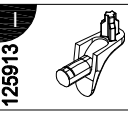

x6

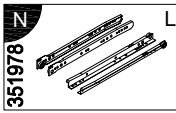

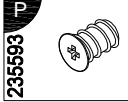

L350  
x2

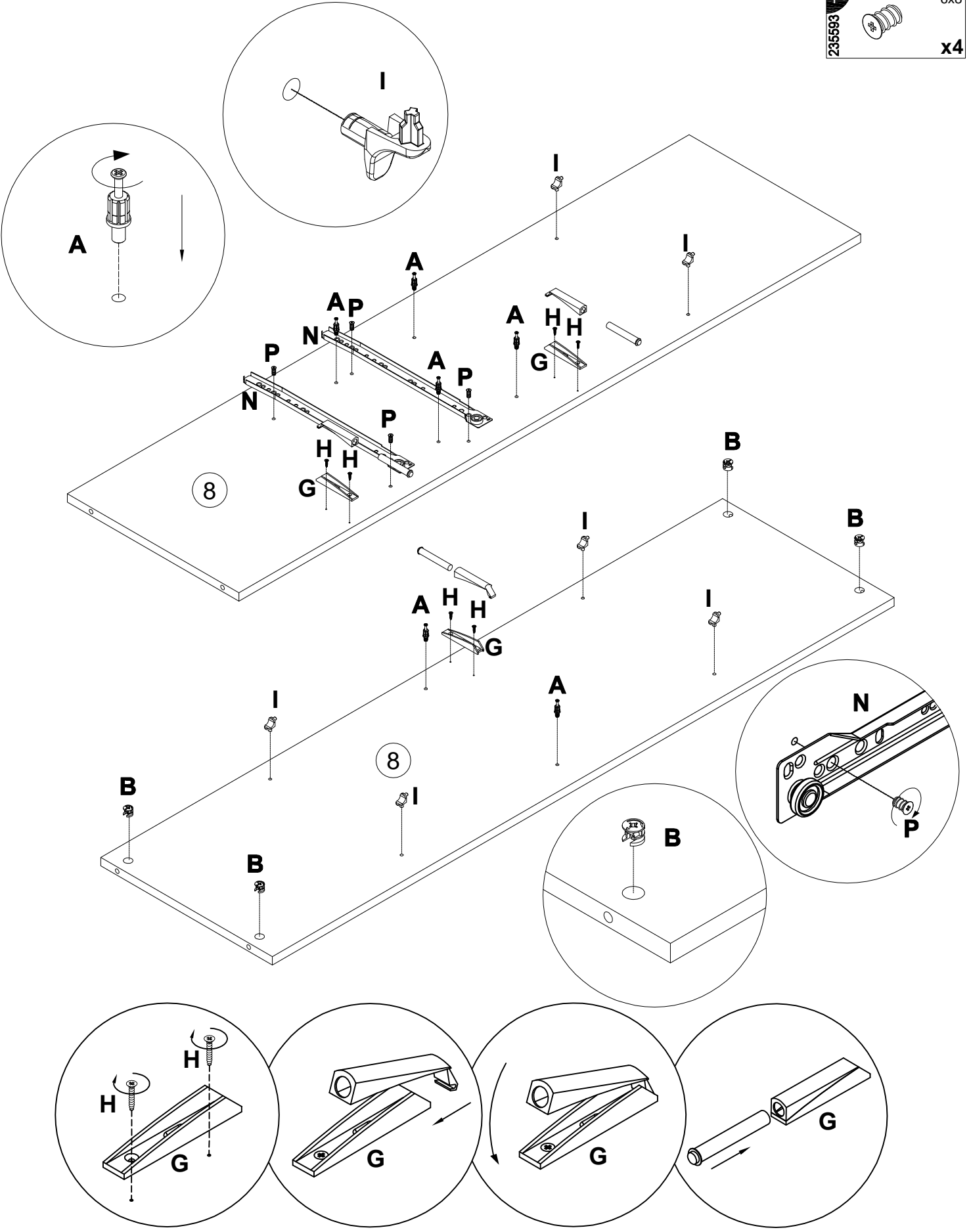

6x8  
x4



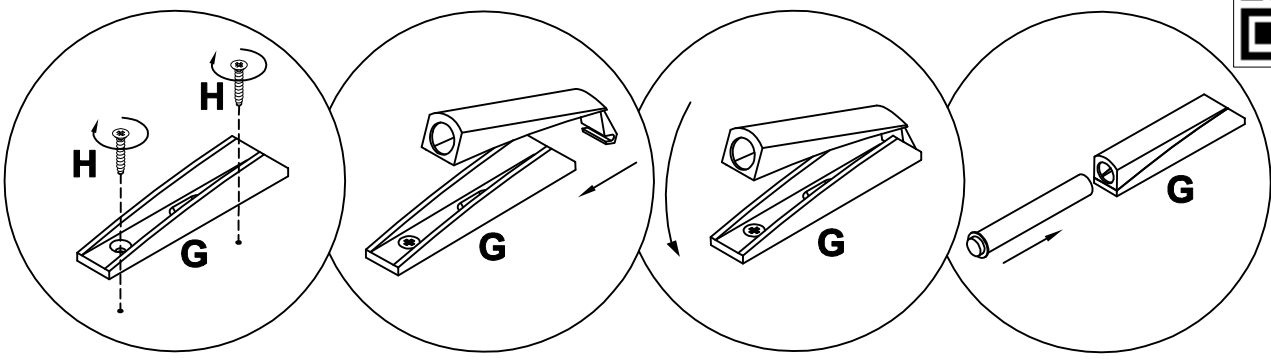
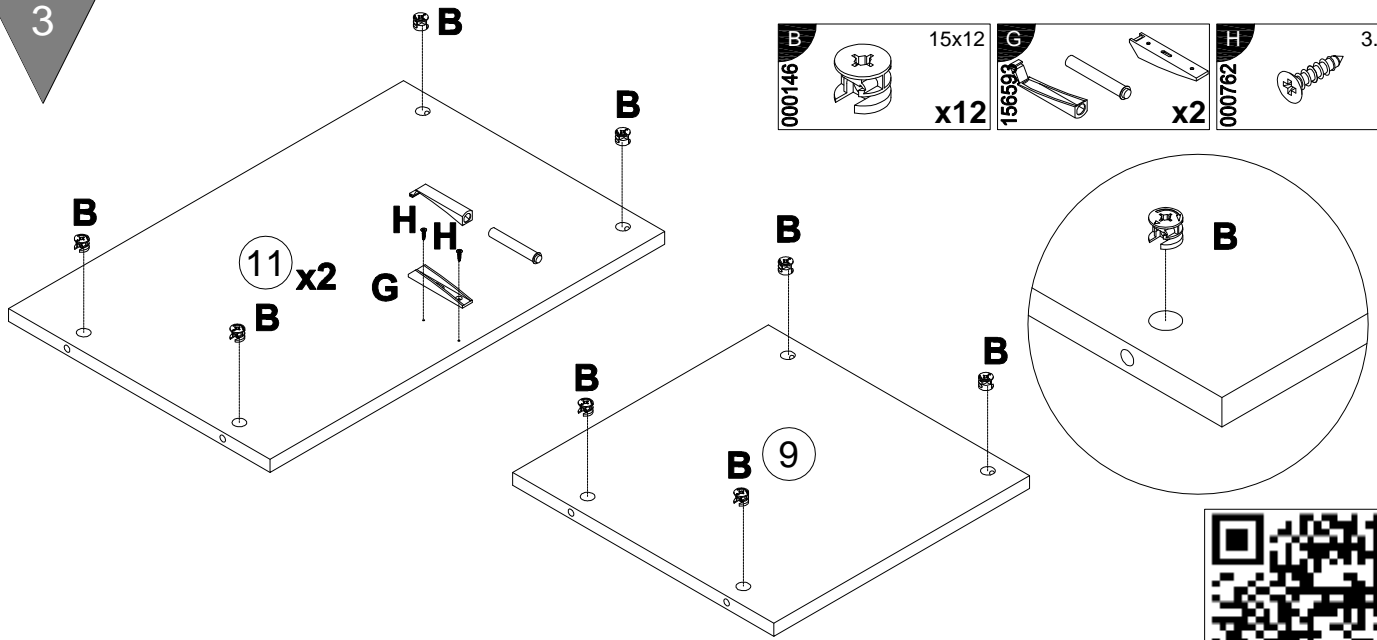

3

<b>B</b>		15x12	<b>G</b>			<b>H</b>		3.5x13
000146		x12	166593		x2	000762		x4



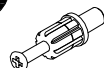

4

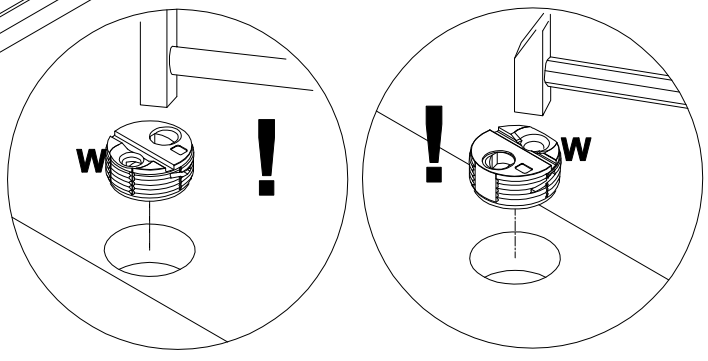
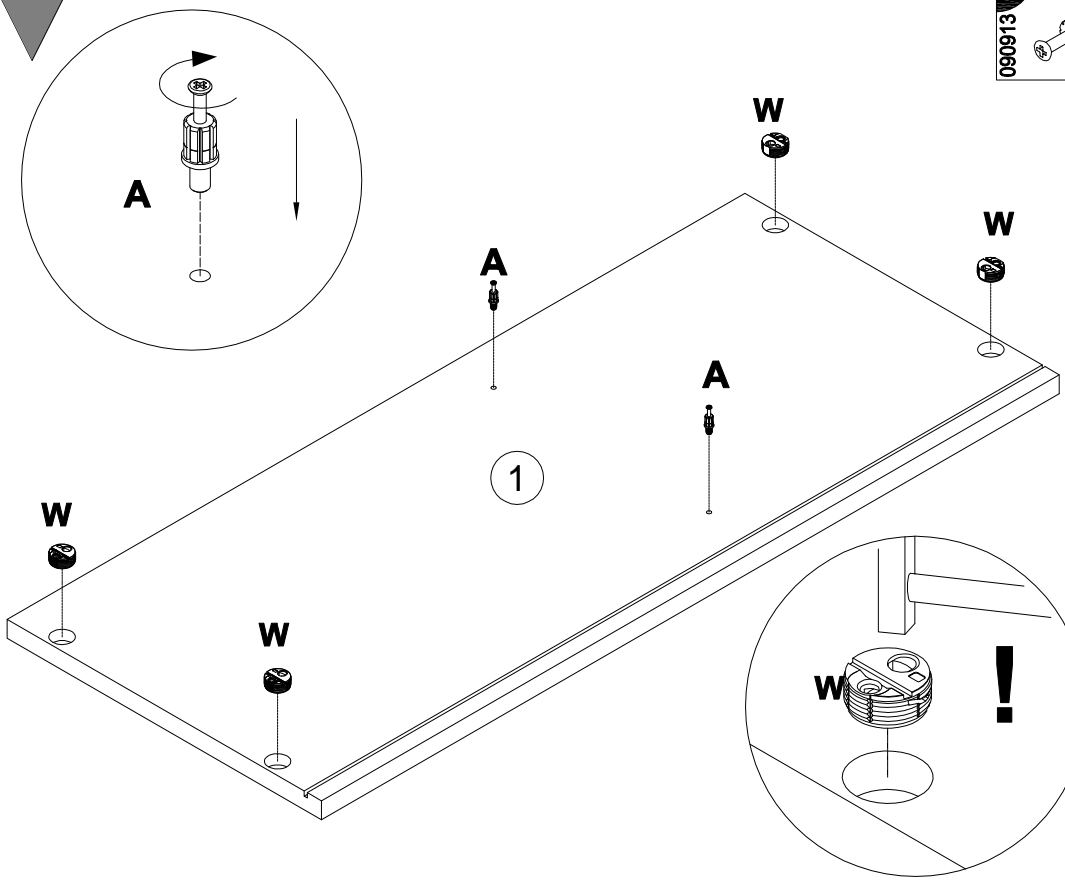
<b>A</b>		7x32	<b>W</b>		
090913		x2	137001		x4

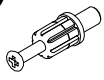

5

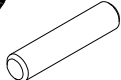
<b>A</b>		7x32	<b>B</b>		15x12	<b>C</b>		8x35
	090913	x2		000146	x4		000151	x4

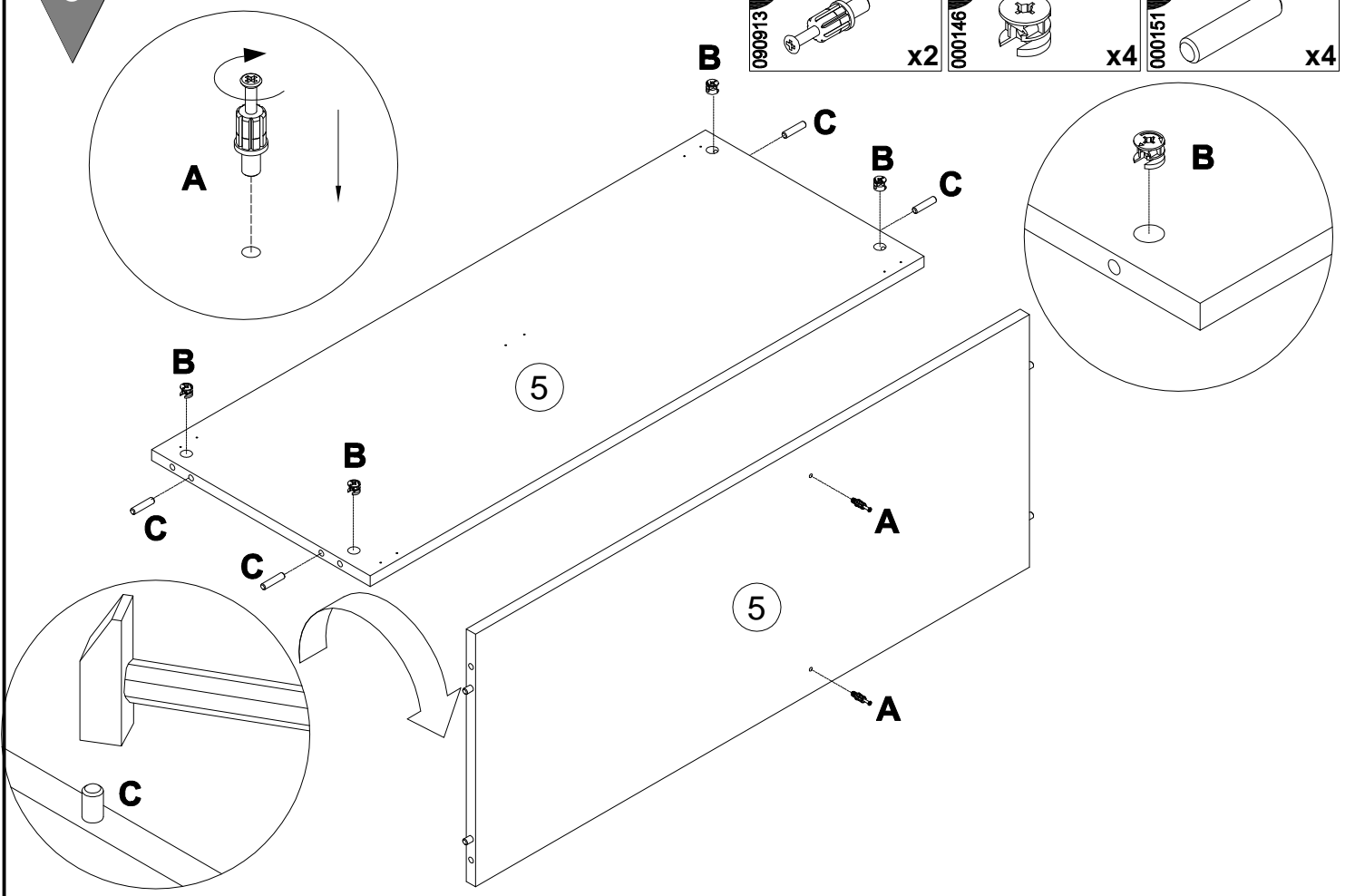

6

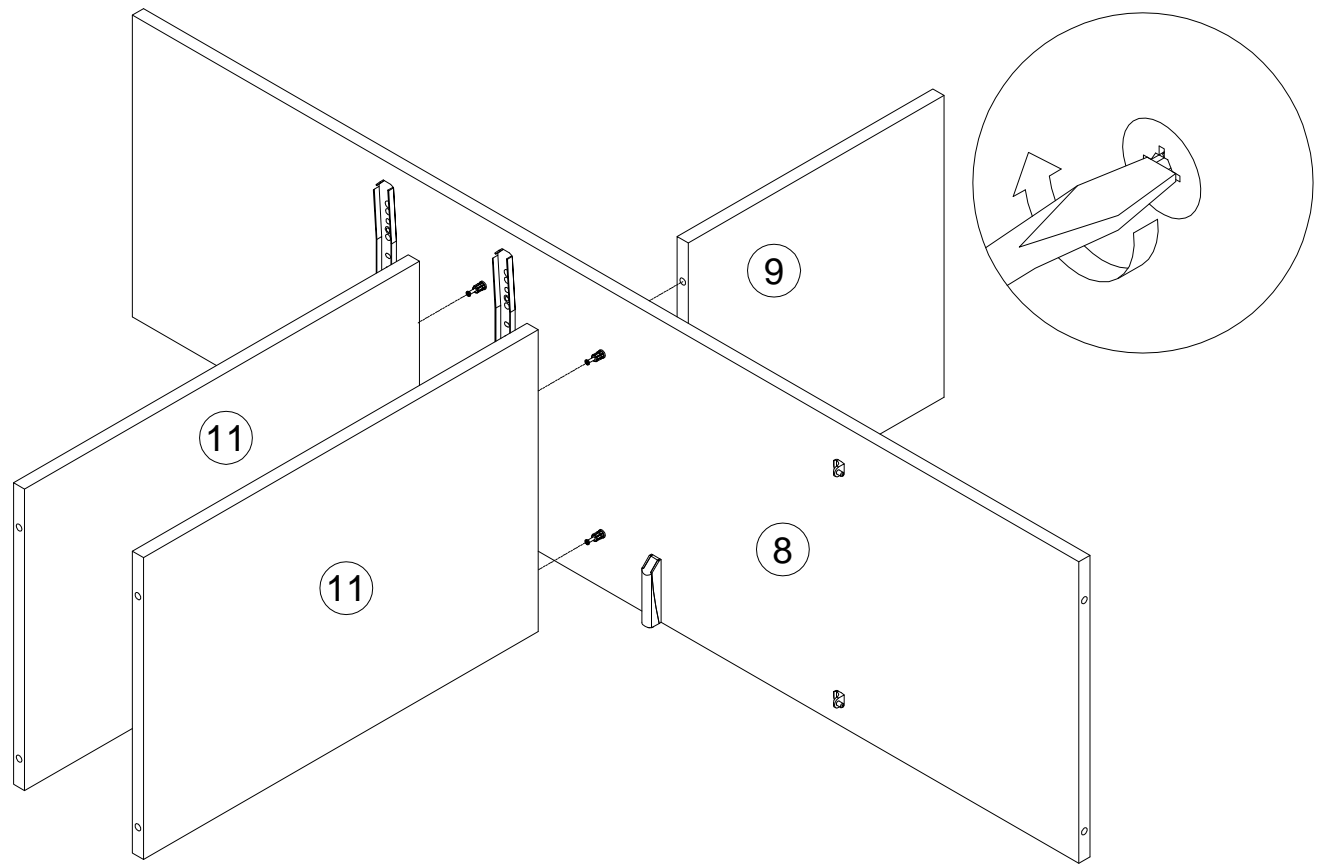

7

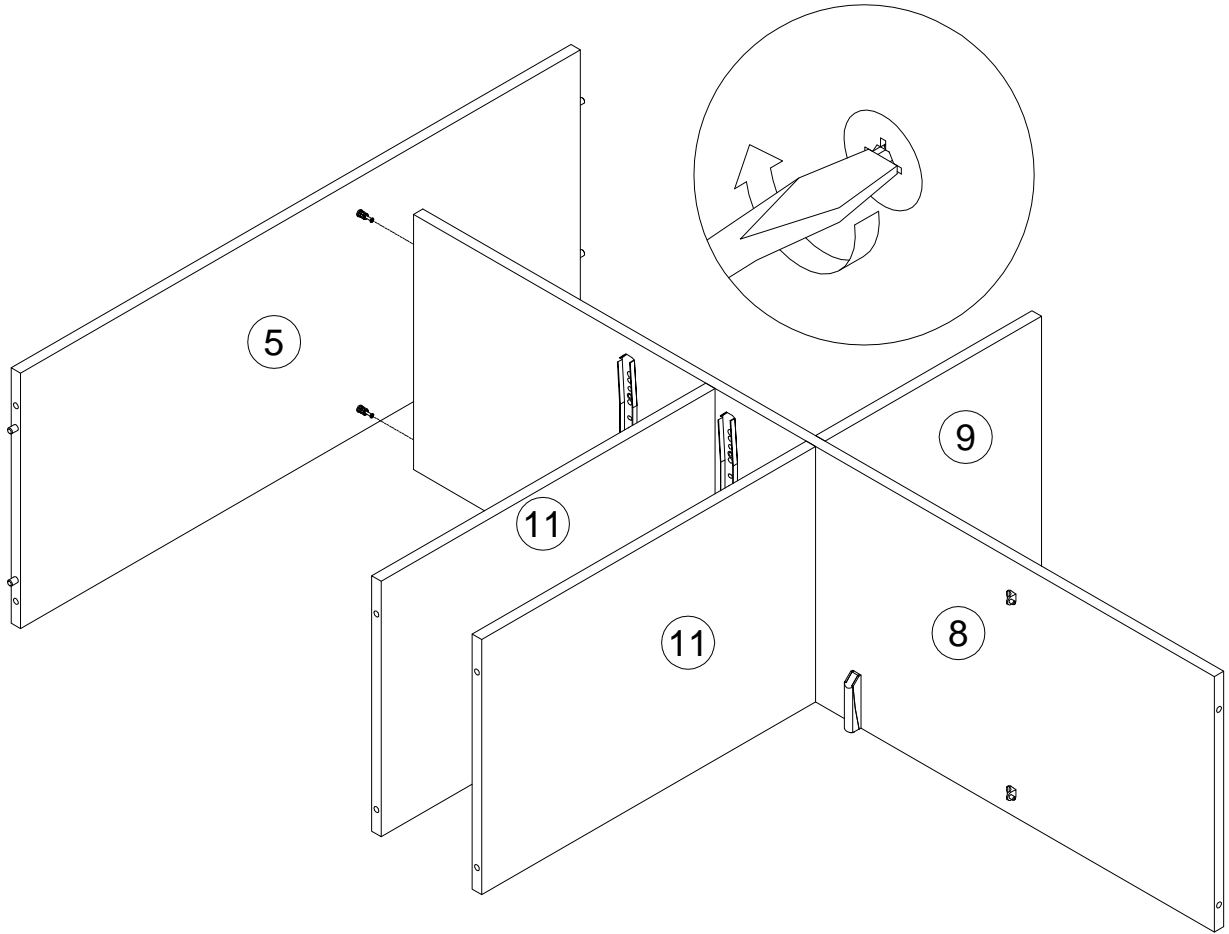

8

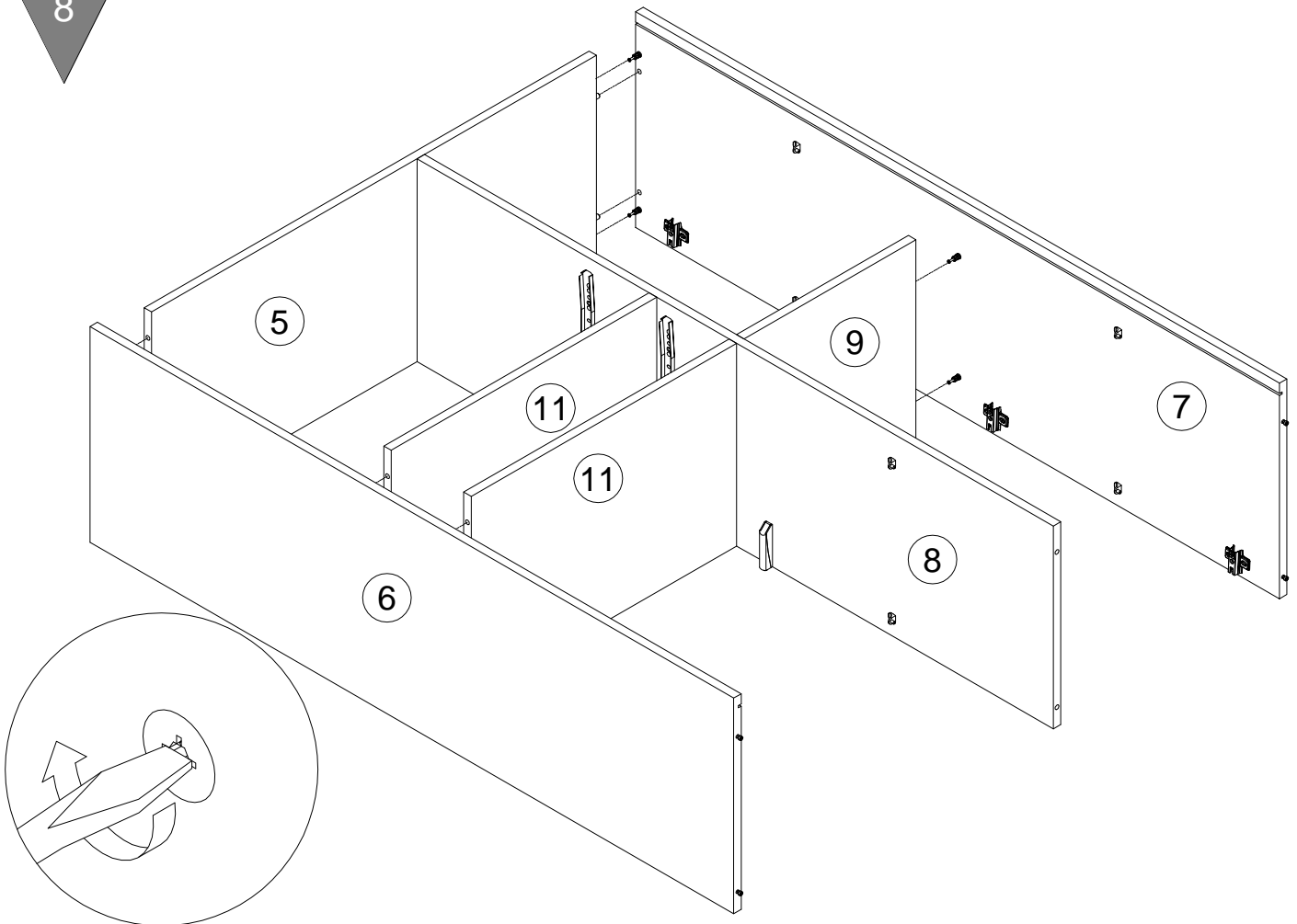

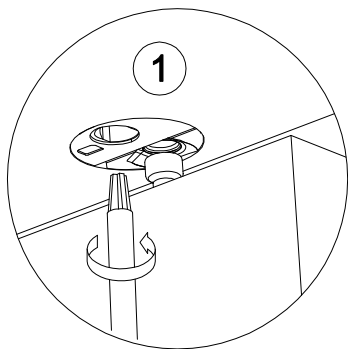
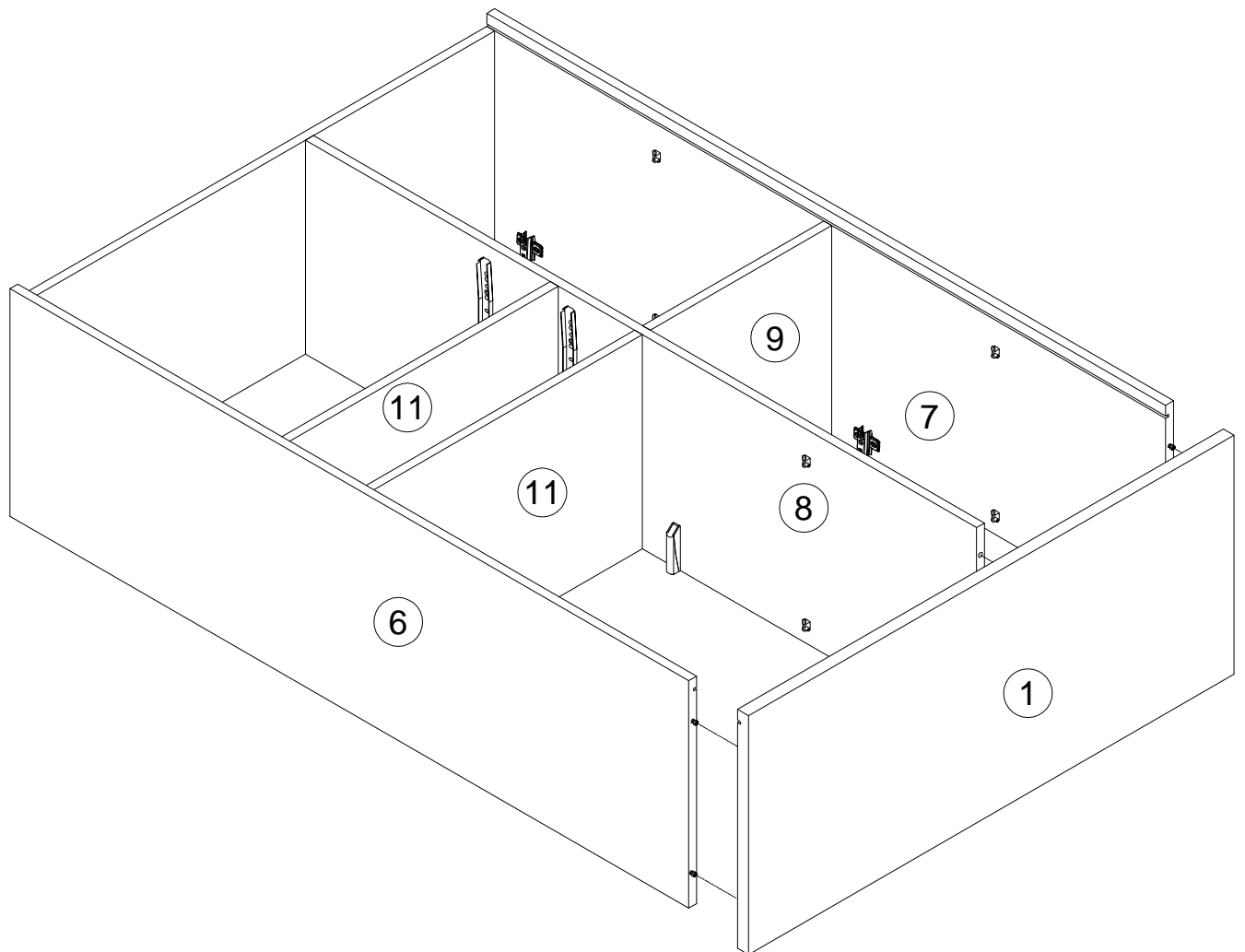

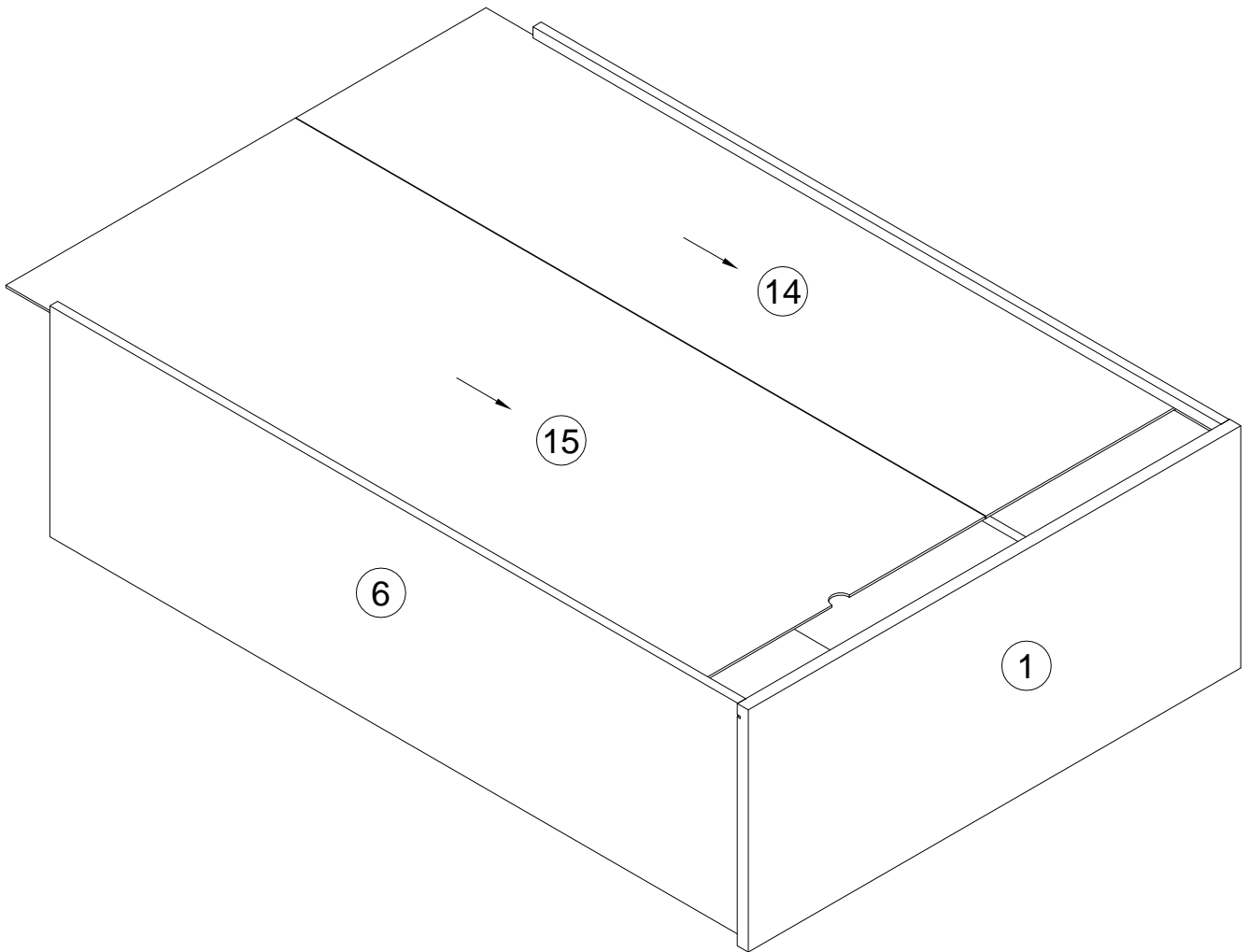

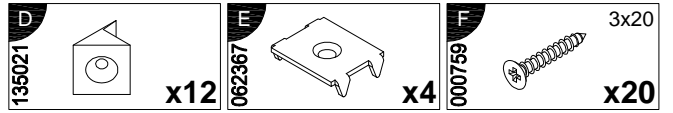



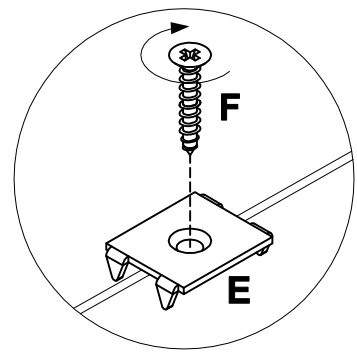
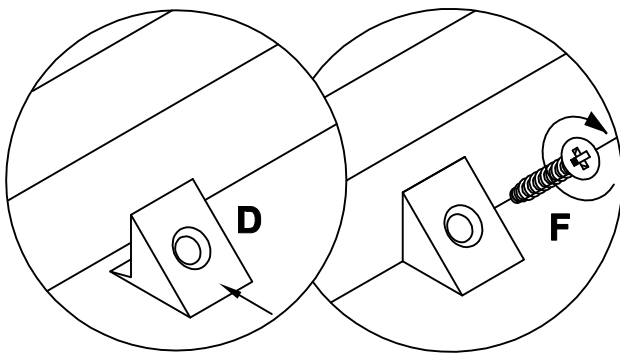
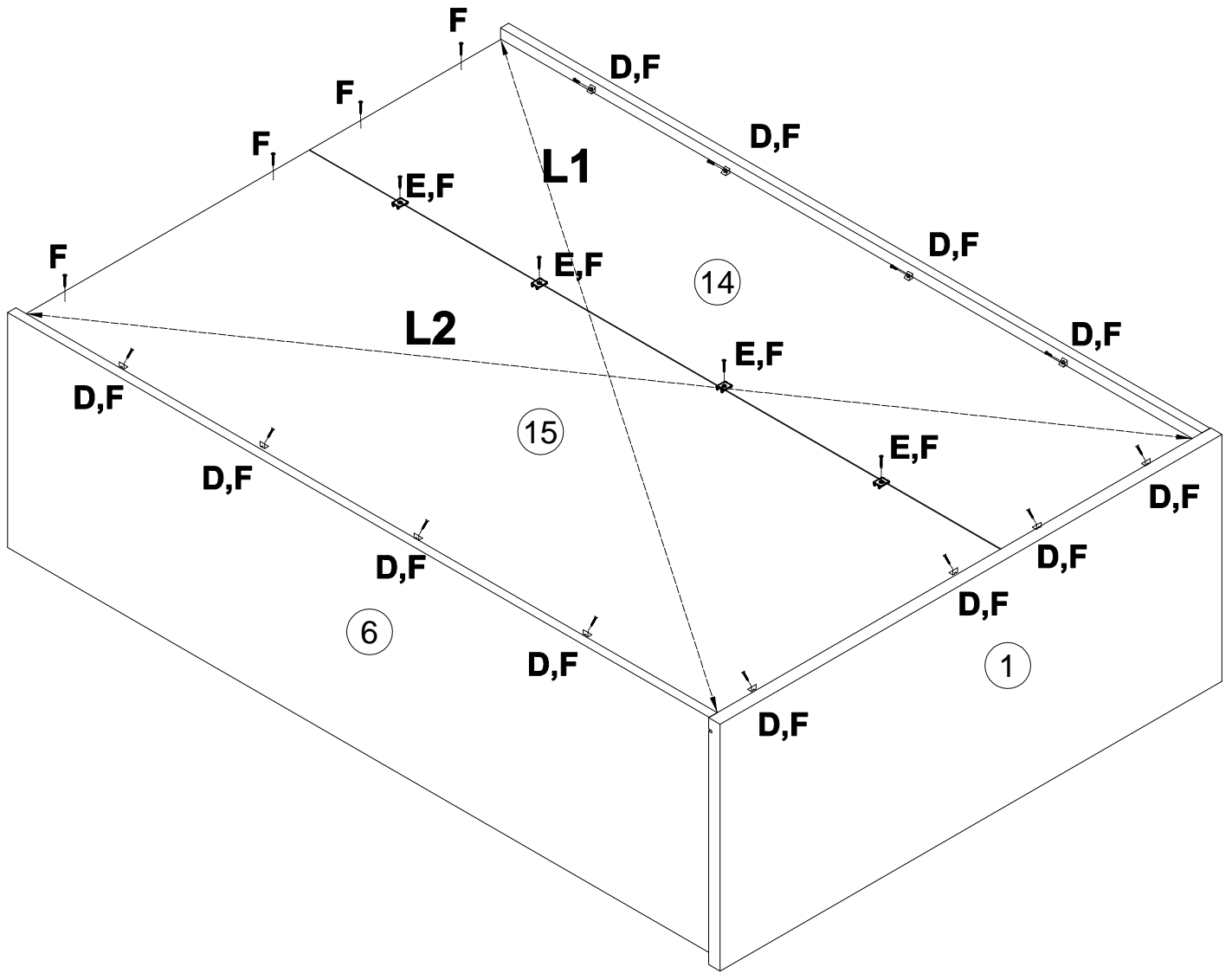

**L1=L2**

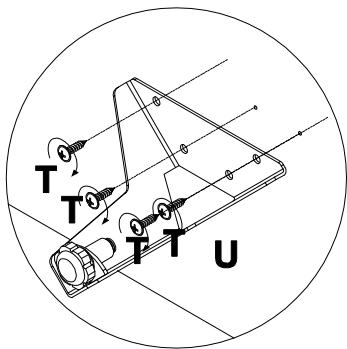
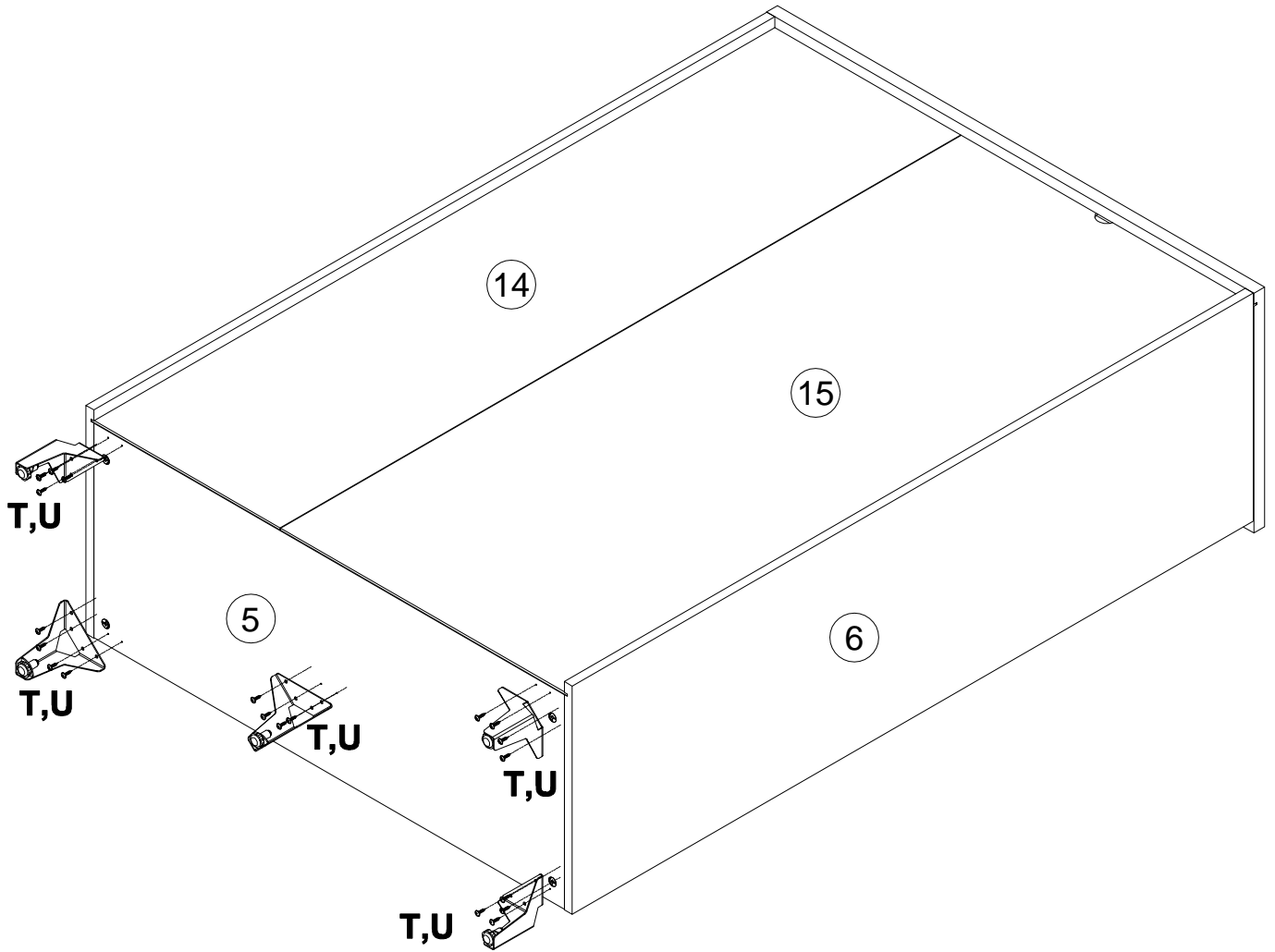
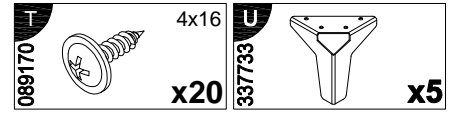

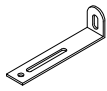



<b>J</b> 155999  <b>x1</b>	<b>K</b> 000754  3.5x16 <b>x2</b>	<b>L</b> 013859  8x40 <b>x1</b>	<b>M</b> 090185  4.5x45 <b>x1</b>
--	--	--	--

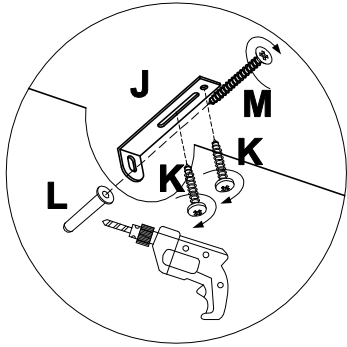

**J,K,L,M**

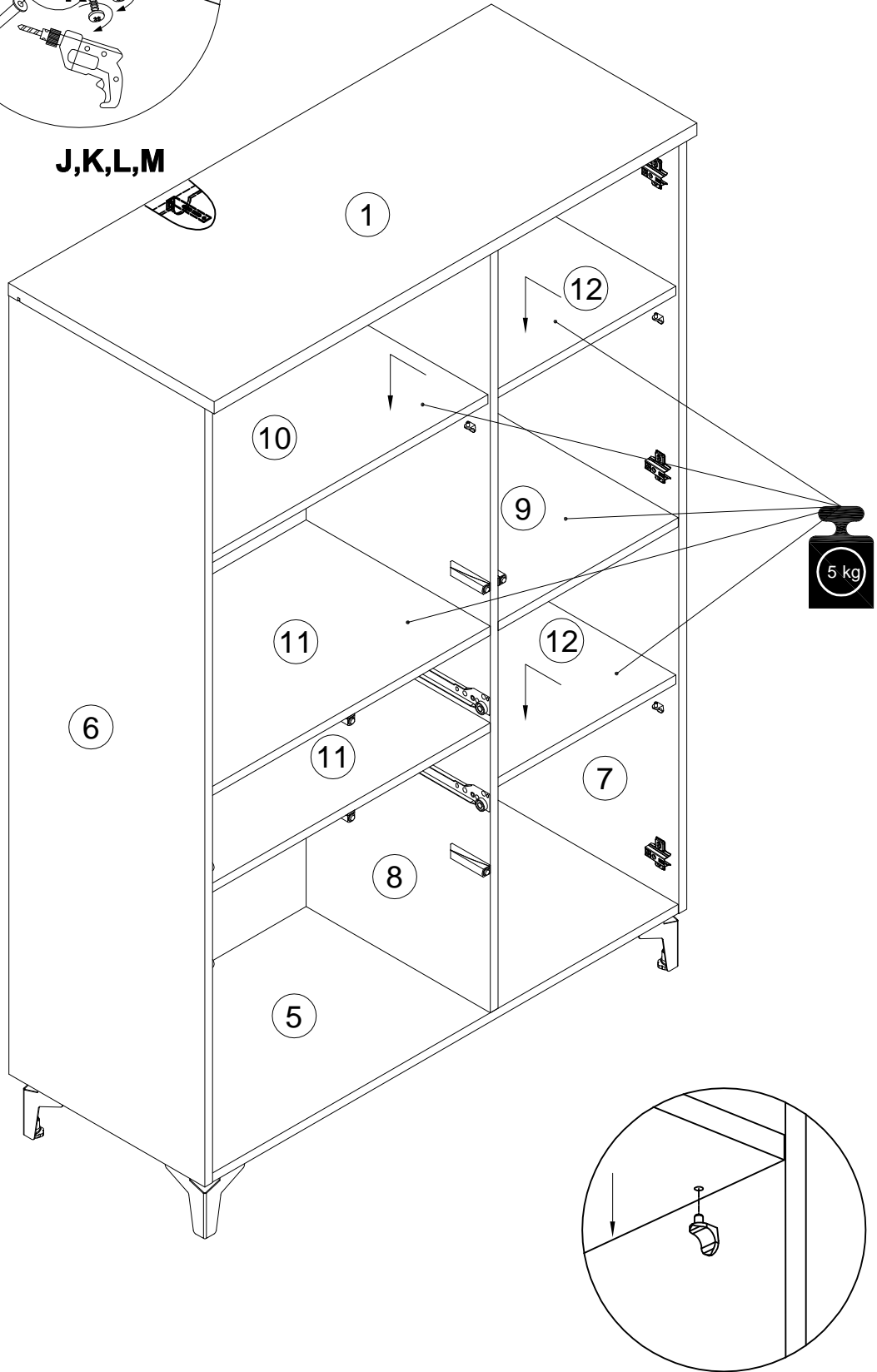

15

x2

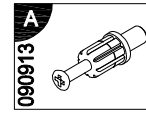

7x32

x8

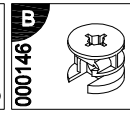

15x12

x8

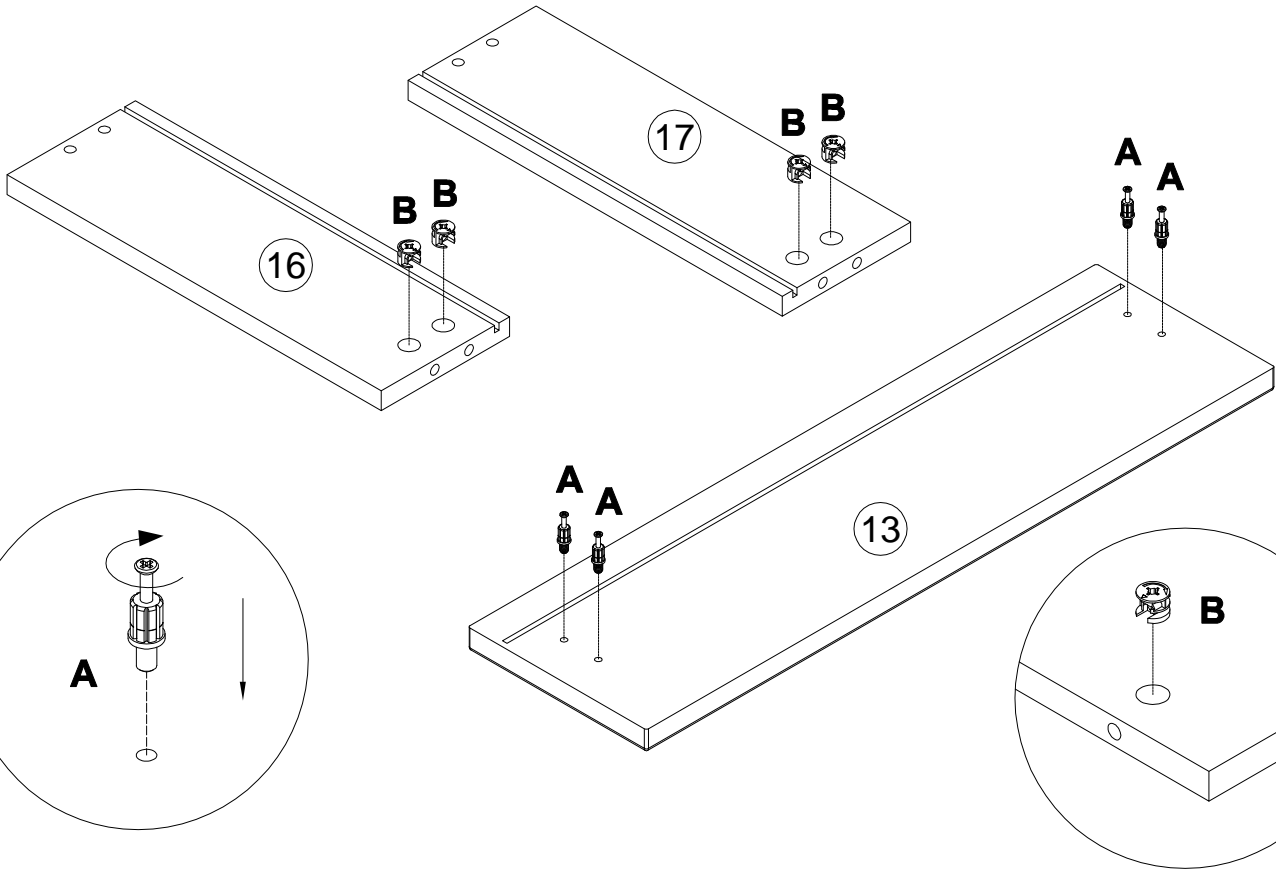

16

x2

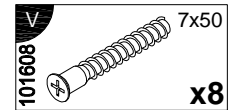

7x50

x8

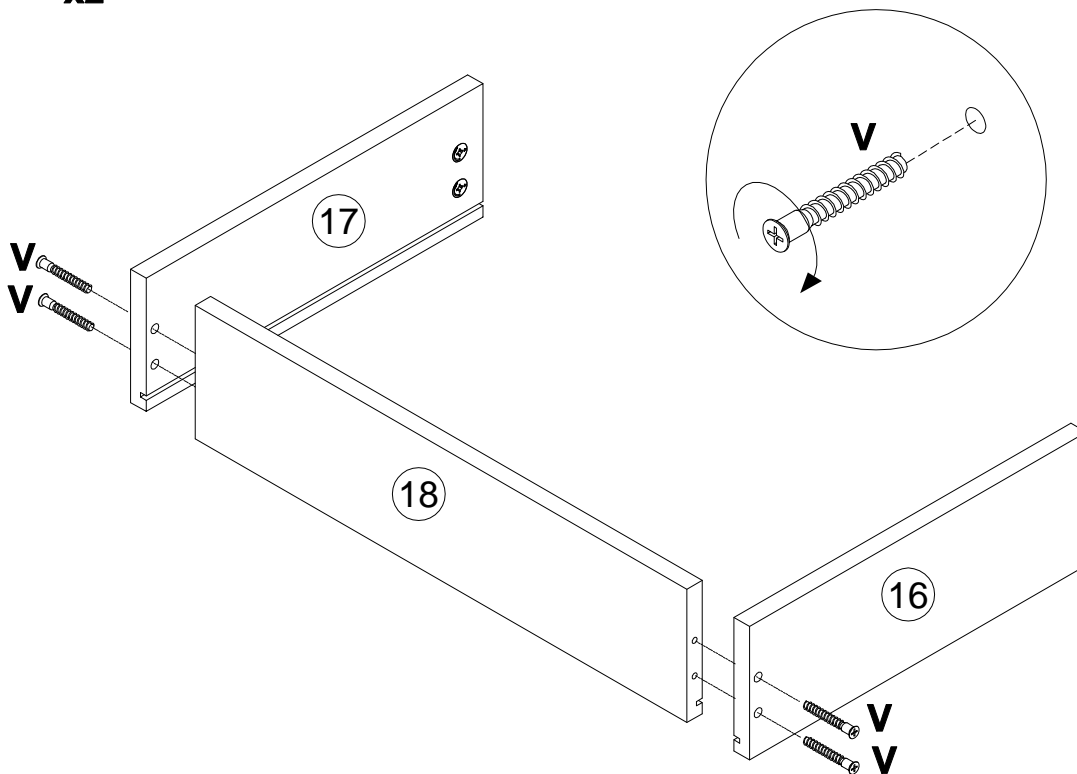

17

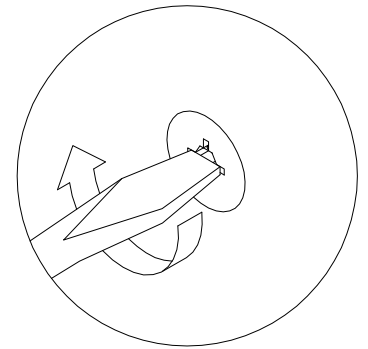
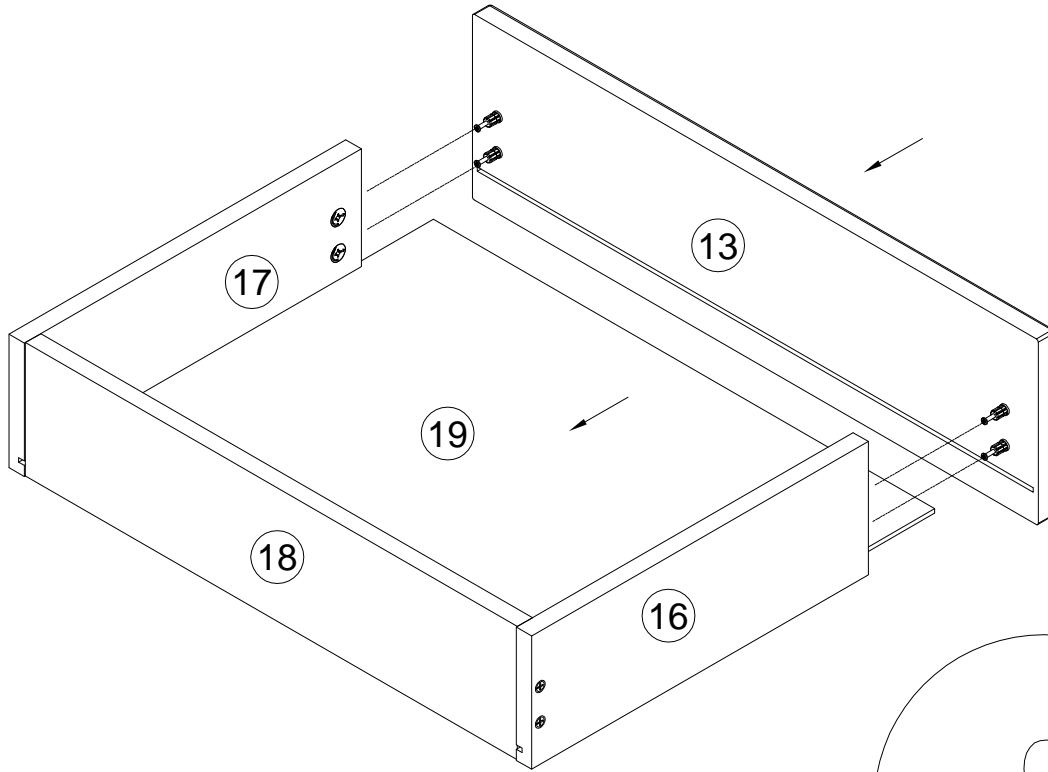

x2

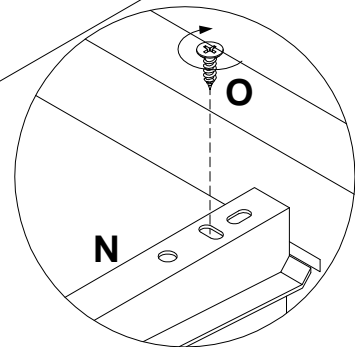
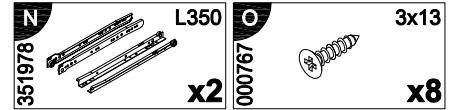
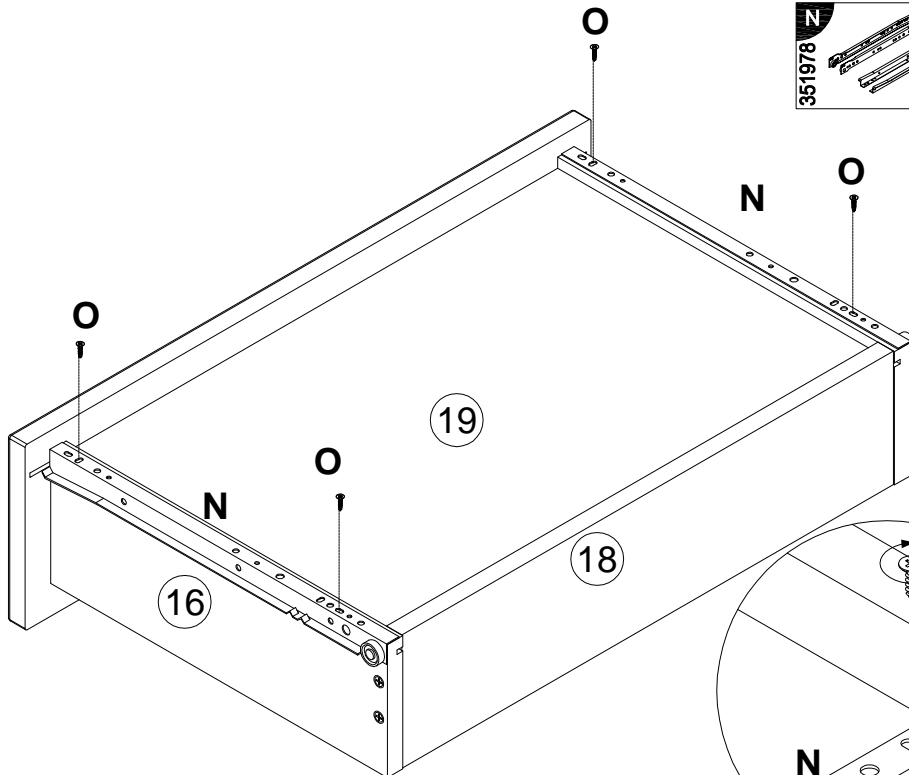

18

x2



Q		x7
S		4x16
010942		x14

